

CARDET-301 Installation Manual

MAGO technology
2025.01.02 revision



1. Introduction

C-301 sensor is a synthetic vehicle detector that is comprised of a magnetic sensor and a digital integral proximity sensor.

C-301 only detects vehicles passing in front of the sensor.

The maximum detection distance between the sensor and a car is **1.8m for a full-sized sedan**. (1.7 m for an economy car)



Never touch or move the sensor while it is running.

2. Installation

2.1 Installation conditions

Height constraint

C-301 sensor should be fixed on a stable fixture with the enclosed head cover, and the installation height will be good at 70-80cm from the surface of the road.

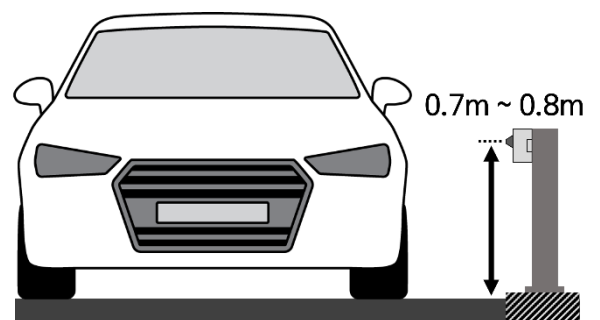

Direction

The sensor must face the side of the vehicle at right angles.

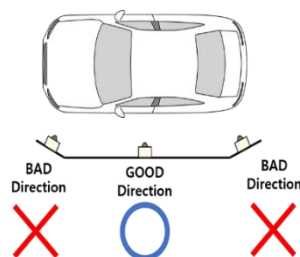

LPR Trigger

When using as an LPR trigger, install the sensor 3.5m to 4.5m in front of the LPR.

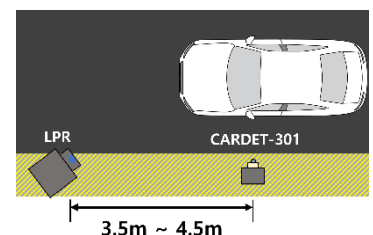

2.2 Caution

- When installing multiple sensors, do not point the sensors at each other.
- Keep a distance of at least 1.8m between the sensors.
- The sensor and controller must be at least 50 cm apart.

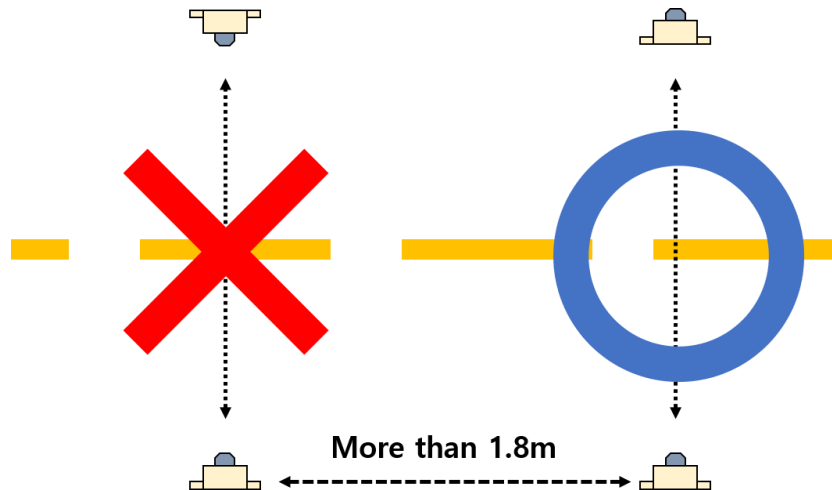

- When mounting the sensor inside the user case, expose the silver protrusion to the outside of the case.
- Drill a hole in the case with a size of at least 24mm.
- Avoid contact between the case and the silver protrusions.



3. Test and Sensor Interface

After fixing the sensor head firmly, apply power without people or vehicles in front of the sensor

- When the vehicle is **detected**, the relay is activated with a 'beep' sound.
- When the vehicle **undetected(passes)**, the relay is turned off with a 'be beep' sound.

Detection also can be checked by the **GREEN LED** in relay controller.

Figure shows the picture of the relay controller for CARDET-301, the controller use **DC 12V** for the power supply, user can use a standard **DC 12V** adaptor (5.5 pi jack).

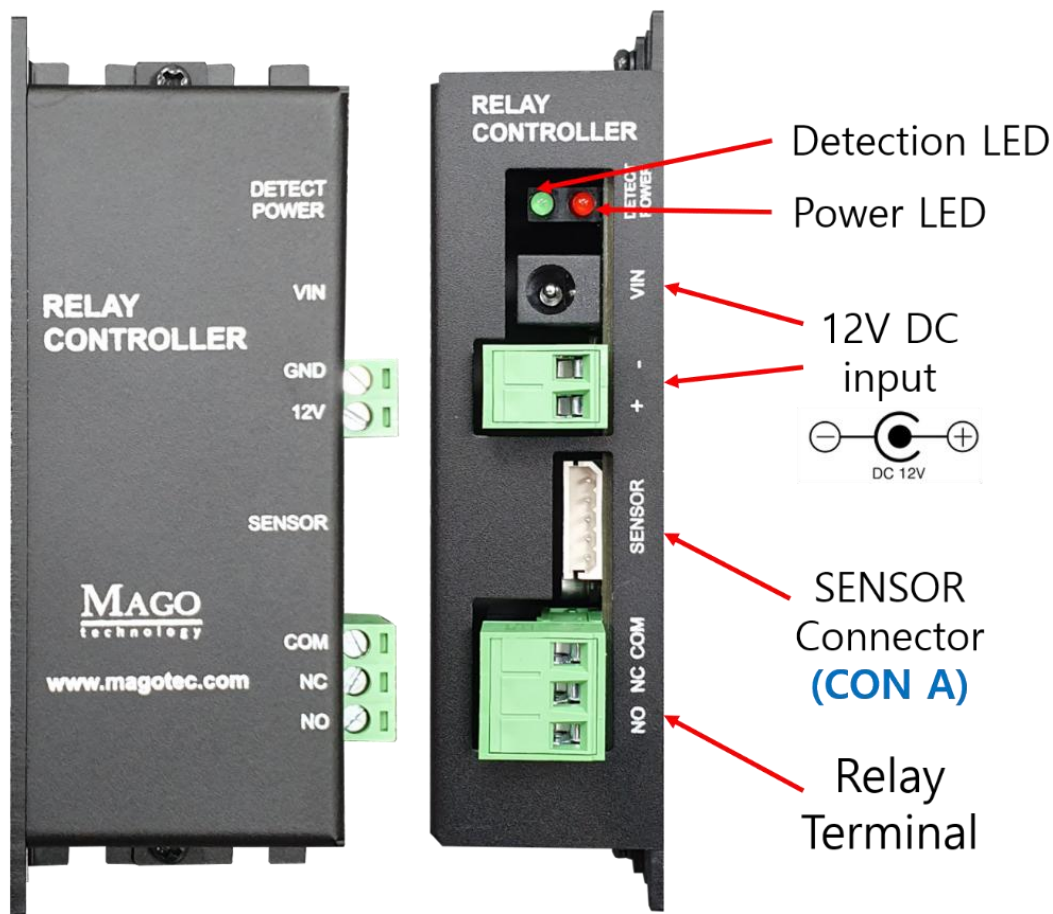

☑ The max capacity of the **power supply** should be **more than 1A**.

If user wants to extend the cable between the sensor head and the relay controller more than 80m, then user should use an adaptor that has a bigger current capacity. Please check the supply voltage drop inside the sensor head (12V) for the case of the cable extension.

The relay controller has a RELAY that makes it easy to interface it to the user's device. The RELAY has a following maximum electrical capability (table 1). Users can use both of **AC** and **DC** to the RELAY.

<Table 1 maximum electrical capability of the RELAY on the relay controller >

	Max voltage	Max current	Max power
DC	30V	3A	90W
AC	220V	2A	440W

Here are two connection examples of the relay controller, the dry contact (RELAY) will enable you to interface easily CARDET to your system.

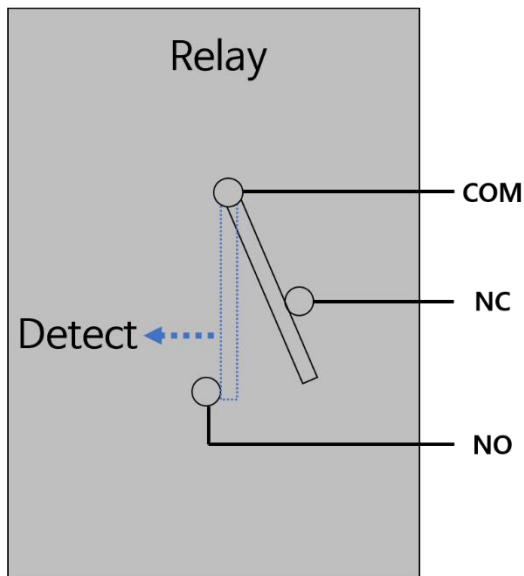

- Relay connection

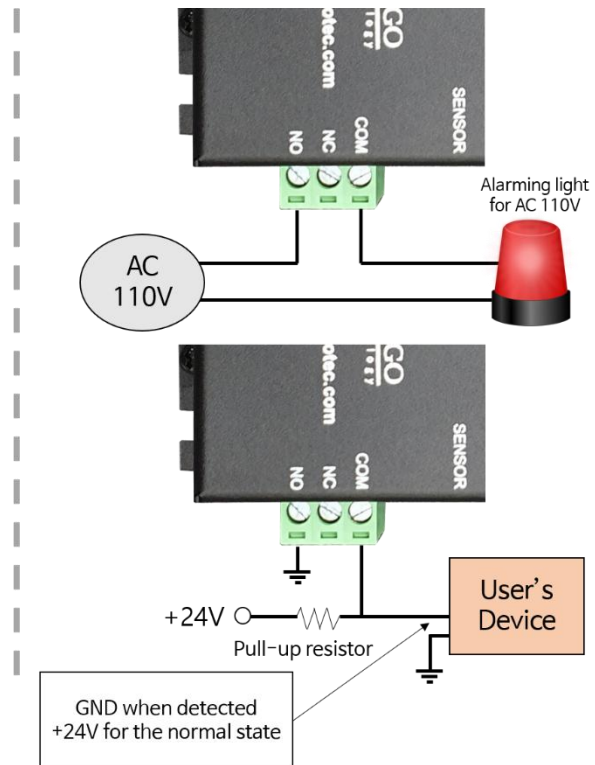

- Connection examples

4. CARDET-301 Sensor output

If you open the upper cover of CARDET-301 sensor module, then you can find a DIP S/W and a small volume as following. User can choose the mode of operations among following 4 modes (table 2).

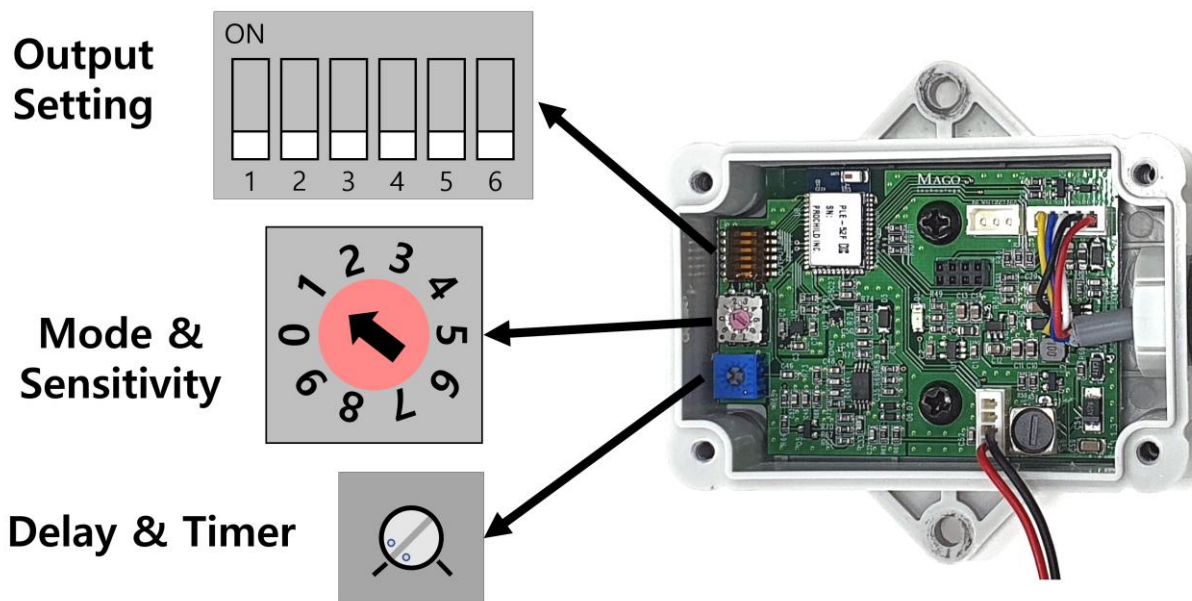

The sensitivity and mode of the sensor can be adjusted by changing the rotary switch setting attached to the sensor. There are 4 modes, **balance / parking bar closing / LPR / parking**. High numbers make the sensor more sensitive. But low numbers make the sensor less sensitive.

<Table 2 Setting of the mode & sensitivity of proximity>

Mode	Switch	Setting	characteristic
Balance	0-2	Balance mode 0(less sensitive) – 1(default sensitivity) – 2(more sensitive)	Can be used in any situation
Parking bar closing	3-5	Parking bar closing 3(less sensitive) – 4(default sensitivity) – 5(more sensitive)	Optimized for parking bar closing control
LPR	6-8	LPR mode 6(less sensitive) – 7(default sensitivity) – 8(more sensitive)	Turns on about 20% faster
Parking	9	Parking mode 9(default sensitivity)	Optimized for parking detection, slow response

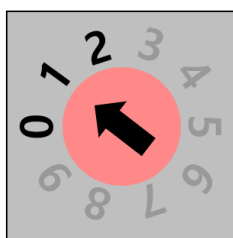

Balance

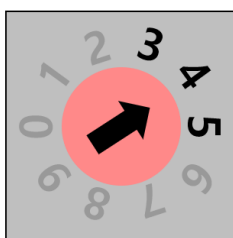

Parking bar closing

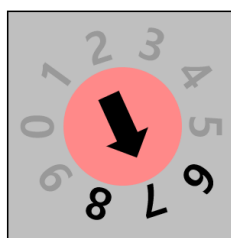



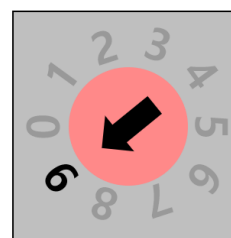

LPR

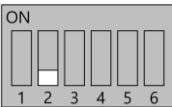
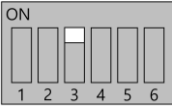

Parking

Sensor should be RESET if setting is changed.

<Table 3 Setting of the output mode of CARDET-301 >

DIP SW	Function	Setting	Description
1			Reserved
2	SHORT PULSE		Automatically OFF after the pre-defined time The width of the time can be adjusted by the volume timer. Short pulse time : Min. 0.5 ~ Max. 30 sec.
			Continuously ON when a vehicle is stopped in front of the sensor. OFF time delay can be adjusted by the volume timer on the PCB OFF delay time : Min. 0.3 ~ Max. 10 sec.
3	Inverted Output		Detected: Relay OFF , Un-detected: Relay ON (Inverted output)
			Detected: Relay ON , Un-detected: Relay OFF (default)
4	Rebound		Rebound function ON Rebound function is a kind of safety function that enables fast detect following vehicle or hanging cart.
			Rebound function OFF
5-6			Reserved

You can set the **OFF delay** or **timer** of the output signal by adjusting the parts below.
Adjust by turning clockwise or counterclockwise using a small flat screwdriver.
Turning it counterclockwise (left) decreases time, and turning it clockwise (right) increases it.

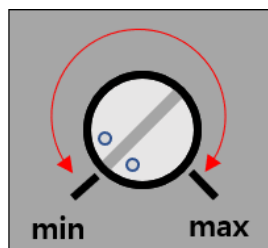

Sensor should be RESET if setting is changed.

5. Sensor Initialization

When a CARDET-301 is powered on, the sensor executes the automatic calibration to make the magnetic map around it on the spot (approx. 3 sec.), so during the calibration, cars should not pass in front of the sensor.

6. Warning

CARDET-301 use Earth magnetic field, so it might make an incorrect operation against severe electromagnet noises, motorcycles, a large size truck, a motor beside the sensor, etc. User should design the whole system will be safe even if the sensor makes a false operation. There is no responsibility for the makers and distributors for safety issues.

7. Specification

<Table 4 specification of CARDET-301 sensor head>

CARDET – 301 Sensor Specification					
Characteristics	Min.	Typical	Max.	Unit	Remark
Power supply		12		Volt	
Current consumption		45		mA	Sensor head only
Operation temp.	-20		+85	Degree	
Detection distance from the sensor head	0.1	1.3	1.8	m	1.8m for a sedan
Cable distance		5	80	m	Case of 1 A (DC12V)

Please contact to sales@magotec.com

